

ECO₂Watt

Great cooling capacity CO₂ condensing units



- ❄ Large maintenance access.
- ❄ No engine room.
- ❄ Custom design.

ECO₂Watt are great cooling capacity CO₂ condensing units, single or double suction transcritical cycle with built-in gas cooler, or in cascade cycle, designed according to the needs of the installation for a total cooling capacity between 80 and 300 kW.

Features

- ▶ Construction in galvanised sheet steel structure with epoxy paint.
- ▶ Sets of CO₂ compressors equipped with rotalock valves.
- ▶ Inverter capacity control per compressor group.
- ▶ Particulate separator and CO₂ filter.
- ▶ Oil separator and accumulator with oil filter and electronic compressor injection.
- ▶ Medium pressure CO₂ receiver (PS: 60 bar) with double safety valve.
- ▶ Economiser - liquid CO₂ subcooler.
- ▶ Instrumentation panel with pressure gauges and load taps.
- ▶ Integrated control and power panel with electronic control unit for compressor and electronic valve management.
- ▶ Emergency unit for CO₂ maintenance.

Transcritical ECO₂Watt

- ▶ Set of transcritical CO₂ compressors and set of compressors in parallel. Inverter drive in one compressor of each set.
- ▶ Double pressure control valve.
- ▶ Pressure regulating valve with medium pressure relief.
- ▶ Internal economiser exchanger.
- ▶ Gas cooler with copper tube coils and aluminium fins in parallel.
- ▶ PS: 120 bar. Variable speed EC axial motor fans.

Cascade ECO₂Watt

- ▶ Up to triple cascade plate heat exchanger with gravity circulation.
- ▶ High temperature refrigerant R-290 or HFC.
- ▶ Semihermetic high temperature compressors, with Inverter drive in one compressor.
- ▶ High temperature circuit made of copper, with filter, sight glass and electronic expansion valves.
- ▶ Copper tube and aluminium finned coil condenser in parallel V configuration.
- ▶ Variable speed EC axial motor fans.

Transcritical cycle with parallel compression

The transcritical cycle with parallel compression improves energy efficiency at high ambient temperatures.

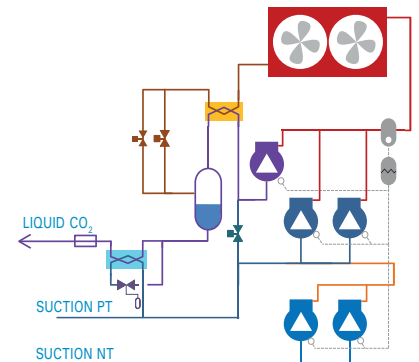

Cascade cycle

The CO₂ cascade cycle with a high temperature cycle of R-290 or HFC offers excellent refrigeration performance in low temperature applications (cold rooms or freezer tunnels).

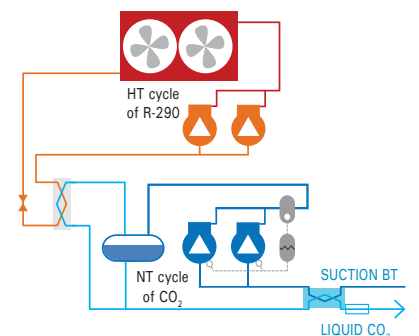

ECO₂Watt dimensions

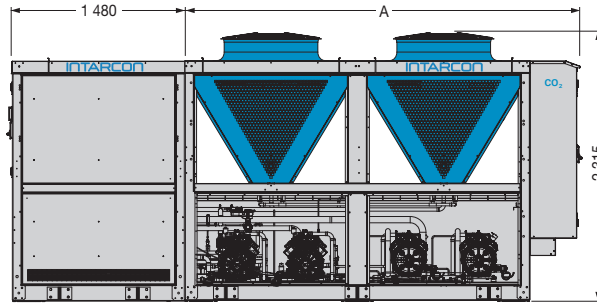
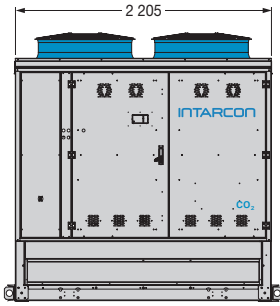

Dimensions (mm)	A
1 series	1 901
2 series	3 377
3 series	4 853
4 series	6 329
5 series	7 380

ECO₂Rack dimensions

1 series

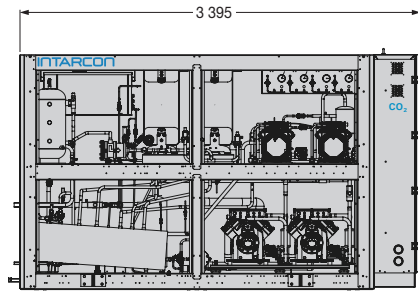
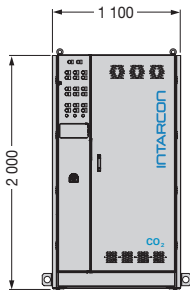

2 series

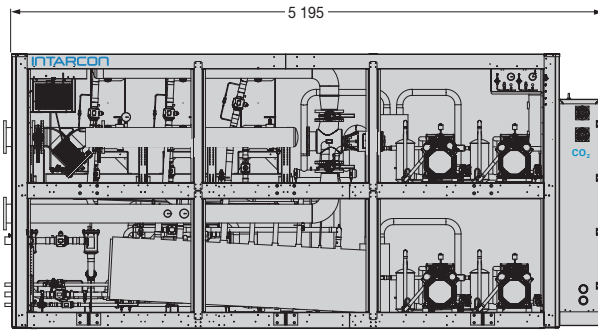
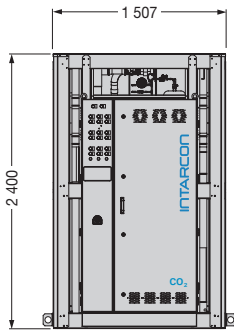

Dimensions in mm.